



2M Async Fast SRAM

CS18FS2048(3/W)

Cover Sheet and Revision Status

版別 (Rev.)	DCC No	生效日 (Eff. Date)	變更說明 (Change Description)	發行人 (Originator)
1.0		Apr.15,2014	New issue	Hank Lin
2.0		Nov. 8, 2021	Revise "Chiplus reserves the right to change product or specification without notice" to "Chiplus reserves the right to change product or specification after approving by customer. "	Hank Lin
3.0	20240007	May. 232024	Delete 5V products	Hank Lin
4.0	20240018	Oct. 22, 2024	Corrected the minimum value of tAS and tWR from 0ns to 1.5ns	Hank Lin



2M Async Fast SRAM

CS18FS2048(3/W)

GENERAL DESCRIPTION	1
FEATURES	1
Order Information.....	2
PIN CONFIGURATIONS.....	4
44TSOP2-400mil	4
6x8mm mini-BGA with ball pitch 0.75mm	4
FUNCTIONAL BLOCK DIAGRAM	5
Absolute Maximum Ratings*	5
Recommended DC Operating Conditions*(T _A =0 to 70°C)	6
DC and Operating Characteristics*(T _A =0 to 70°C).....	6
Capacitance*(T _A = 25°C, f= 1.0MHz)	7
Test Conditions*	8
Functional Description (x8 Mode)	9
Functional Description (x16 Mode).....	9
Data Retention Characteristics*(T _A =0 to 70°C).....	10
Data Retention Wave form	10
Read Cycle*	11
Write Cycle*	12
Timing Diagram	13
Timing Waveform of Read Cycle (1) (Address Controlled, $\overline{CS} = \overline{OE} = V_{IL}$, $\overline{WE} = V_{IH}$, \overline{UB} , $\overline{LB} = V_{IL}$ **).	13
Timing Waveform of Read Cycle (2) ($\overline{WE} = V_{IH}$).....	13
Timing Waveform of Write Cycle (1) (\overline{OE} Clock).....	14
Timing Waveform of Write Cycle (2) ($\overline{OE} = \text{Low fixed}$).....	15
Timing Waveform of Write Cycle (3) ($\overline{CS} = \text{Controlled}$)	15
Timing Waveform of Write Cycle (4) (\overline{UB} , \overline{LB} Controlled)	16
Package outline dimensions	17



2M Async Fast SRAM

CS18FS2048(3/W)

GENERAL DESCRIPTION

The CS16FS2048(3/W) and CS18FS2048(3/W) are a 2,097,152-bit high-speed Static Random Access Memory organized as 128K(256) words by 16(8) bits. The CS16FS2048(3/W) (CS18FS2048(3/W)) uses 16(8) common input and output lines and have an output enable pin which operates faster than address access time at read cycle, And CS16FS2048(3/W) allows that lower and upper byte access by data byte control(\overline{UB} , \overline{LB}). The device is fabricated using advanced CMOS process, 6-TR based cell technology and designed for high-speed circuit technology. It is particularly well suited for use in high-density high-speed system applications. The CS16FS2048(3/W) is packaged in a 400mil 44-pin TSOP2 and 48FBGA. The CS18FS2048(3/W) is packaged in a 400mil 44-pin TSOP2 and 36FBGA.

FEATURES

- Fast Access Time 8,10,12,15ns(Max)
- CMOS Low Power Dissipation
Standby (TTL): 10mA (Max.)
(CMOS): 6mA (Max.)
Operating: 35mA (8ns, Max..)
: 30mA(10ns ,Max.)
- Single 3.3±0.3V Power Supply
- Wide range (1.65V~3.6V) of Power Supply
- TTL Compatible inputs and Outputs
- Fully Static Operation, No Clock or Refresh required
- Three State Outputs
- Data Byte Control(x16 Mode)
 \overline{LB} : I/O₀~I/O₇, \overline{UB} : I/O₈~I/O₁₅
- Standard 44TSOP2 and 36FBGA Package Pin Configuration for 256k x 8
- Standard 44TSOP2 and 48FBGA Package Pin Configuration for 128k x 16
- Operating in Commercial and Industrial Temperature range.



2M Async Fast SRAM

CS16FS2048(3/W)

Order Information

Density	Org.	Part Number	V _{CC} (V)	Speed		Package	Temp.
				t _{AA} (ns)	t _{OE} (ns)		
2Mb	128Kx16	CS16FS20483GC(I)-08	3.3	8	4	44 TSOP2	C : Commercial I : Industrial
			3.3	8	4	44 TSOP2	
		CS16FS2048WGC(I)-08*	2.5	10	5	44 TSOP2	
			1.8	12	6	44 TSOP2	
		CS16FS20483HC(I)-08	3.3	8	4	48 FBGA	
			3.3	8	4	48 FBGA	
		CS16FS2048WHC(I)-08*	2.5	10	5	48 FBGA	
			1.8	12	6	48 FBGA	
		CS16FS20483GC(I)-10	3.3	10	5	44 TSOP2	
			3.3	10	5	44 TSOP2	
		CS16FS2048WGC(I)-10*	2.5	10	5	44 TSOP2	
			1.8	12	6	44 TSOP2	
		CS16FS20483HC(I)-10	3.3	10	5	48 FBGA	
			3.3	10	5	48 FBGA	
		CS16FS2048WHC(I)-10*	2.5	10	5	48 FBGA	
			1.8	12	6	48 FBGA	



2M Async Fast SRAM

CS18FS2048(3/W)

Density	Org.	Part Number	V _{CC} (V)	Speed		Package	Temp.
				t _{AA} (ns)	t _{oE} (ns)		
2Mb	256Kx8	CS18FS20483GC(I)-08	3.3	8	4	44 TSOP2	C : Commercial I : Industrial
			3.3	8	4	44 TSOP2	
		CS18FS2048WGC(I)-08*	2.5	10	5	44 TSOP2	
			1.8	12	6	44 TSOP2	
		CS18FS20483YC(I)-08	3.3	8	4	36 FBGA	
			3.3	8	4	36 FBGA	
		CS18FS2048WYC(I)-08*	2.5	10	5	36 FBGA	
			1.8	12	6	36 FBGA	
		CS18FS20483GC(I)-10	3.3	10	5	44 TSOP2	
			3.3	10	5	44 TSOP2	
		CS18FS2048WGC(I)-10*	2.5	10	5	44 TSOP2	
			1.8	12	6	44 TSOP2	
		CS18FS20483YC(I)-10	3.3	10	5	36 FBGA	
			3.3	10	5	36 FBGA	
		CS18FS2048WYC(I)-10*	2.5	10	5	36 FBGA	
			1.8	12	6	36 FBGA	

*means max. speed



2M Async Fast SRAM

CS18FS2048(3/W)

PIN CONFIGURATIONS

44TSOP2-400mil

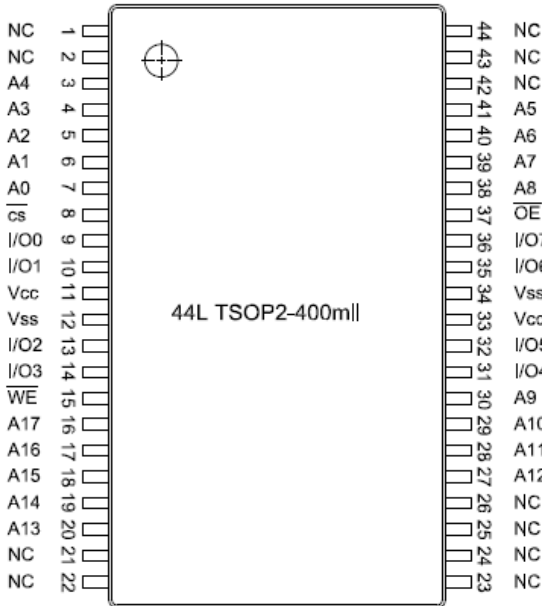

CS18FS2048(3/5/W)- (256k x 8)

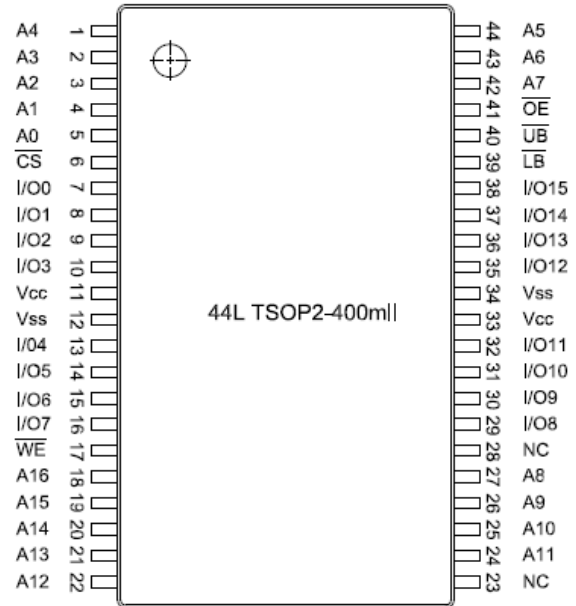

CS16FS2048(3/5/W)- (128k x 16)

6x8mm mini-BGA with ball pitch 0.75mm

	1	2	3	4	5	6
A	A0	A1	NC	A3	A6	A8
B	IO4	A2	WE	A4	A7	IO0
C	IO5		NC	A5		IO1
D	Vss					Vcc
E	Vcc					Vss
F	IO6		NC	A17		IO2
G	IO7	OE	CS	A16	A15	IO3
H	A9	A10	A11	A12	A13	A14

CS18FS2048(3/W) – (256k x 8)
36 ball mini-BGA

	1	2	3	4	5	6
A	LB	OE	A0	A1	A2	NC
B	IO8	UB	A3	A4	CS	IO0
C	IO9	IO10	A5	A6	IO1	IO2
D	Vss	IO11	NC	A7	IO3	Vcc
E	Vcc	IO12	NC	A16	IO4	Vss
F	IO14	IO13	A14	A15	IO5	IO6
G	IO15	NC	A12	A13	WE	IO7
H	NC	A8	A9	A10	A11	NC

CS16FS2048(3/W) – (128k x 16)
48ball mini-BGA



2M Async Fast SRAM

CS18FS2048(3/W)

FUNCTIONAL BLOCK DIAGRAM

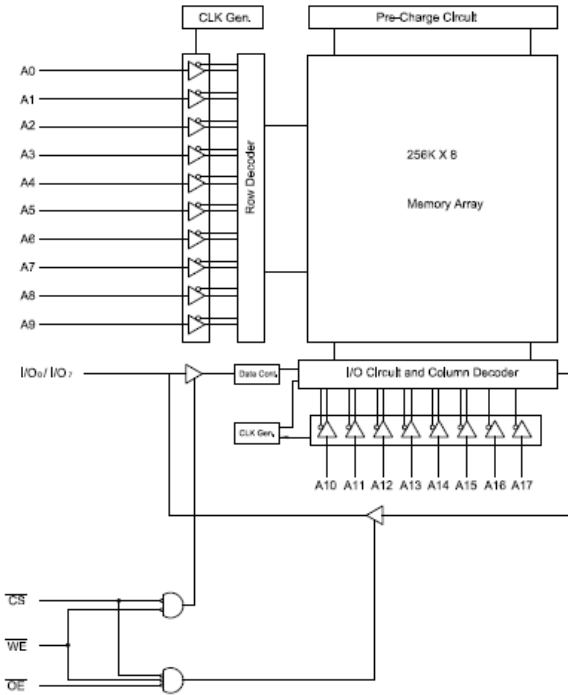

CS18FS2048(3/W) – (256k x 8)

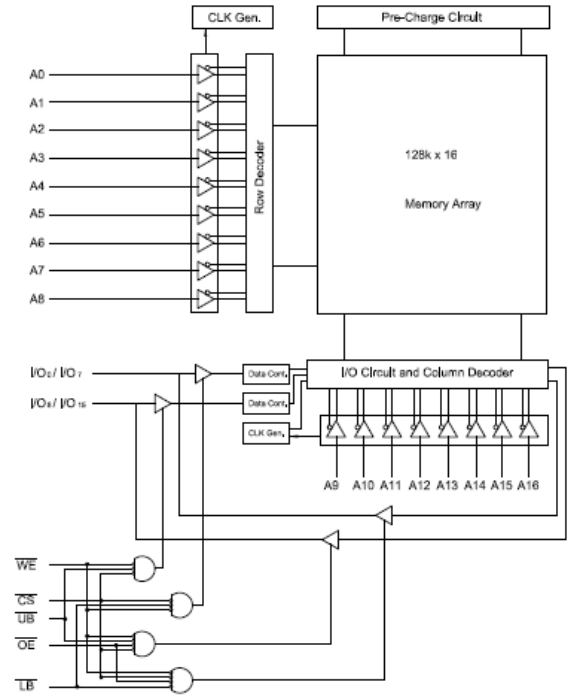

CS16FS2048(3/W) – (128k x 16)

Absolute Maximum Ratings*

Parameter		Symbol	Rating	Unit
Voltage on Any Pin Relative to V _{SS}	3.3V Product	V _{in} , V _{OUT}	-0.5 to V _{CC} +0.5V	V
	Wide V _{CC} ** Product			
Voltage on V _{CC} Supply Relative to V _{SS}	3.3V Product	V _{in} , V _{OUT}	-0.5 to 4.0	V
	Wide V _{CC} ** Product		-0.5 to 4.0	
Power Dissipation		P _D	1.0	W
Storage Temperature		T _{STG}	-65 to 150	°C
Operating Temperature Commercial		T _A	0 to 70	°C
Industrial		T _A	-40 to 85	°C

*Stresses greater than those listed under "Absolute Maximum Ratings" may cause permanent damage to the



2M Async Fast SRAM

CS18FS2048(3/W)

device. This is a stress rating only and functional operation of the device at these or any other conditions above those indicated in the operating sections of this specification is not implied.

Exposure to absolute maximum rating conditions for extended periods may affect reliability.

**Wide VCC Range is 1.65V~3.6V

Recommended DC Operating Conditions*($T_A=0$ to 70°C)

Parameter	Operating V _{CC} (V)	Symbol	Min.	Typ.	Max.	Unit
Supply Voltage	3.3	V _{CC}	3.0	3.3	3.6	V
	Wide 2.4~3.6	V _{CC}	2.4	2.5/3.3	3.6	
	Wide 1.65~2.2	V _{CC}	1.65	1.8	2.2	
Ground		V _{SS}	0	0	0	V
Input High Voltage	3.3	V _{IH}	2.0	-	V _{CC} +0.5	V
	Wide 2.4~3.6	V _{IH}	2.0	-	V _{CC} +0.3	
	Wide 1.65~2.2	V _{IH}	1.4	-	V _{CC} +0.2	
Input Low Voltage	3.3	V _{IL}	-0.3	-	0.8	V
	Wide 2.4~3.6	V _{IL}	-0.3	-	0.7	
	Wide 1.65~2.2	V _{IL}	-0.2	-	0.4	

*The above parameters are also guaranteed for industrial temperature range.

DC and Operating Characteristics*($T_A=0$ to 70°C)

Parameter	Symbol	Test Conditions	Min	Max	Unit	
Input Leakage Current	I _{LI}	V _{IN} =V _{SS} to V _{CC}	-2	2	uA	
Output Leakage Current**	I _{LO}	$\overline{CS}=V_{IH}$ or $\overline{OE}=V_{IH}$ or $\overline{WE}=V_{IL}$ V _{OUT} =V _{SS} to V _{CC}	-2	2	uA	
Operating Current**	I _{CC}	Min.Cycle, 100% Duty $\overline{CS}=V_{IL}$, V _{IN} =V _{IH} or	8ns	-	32	mA
			10ns	-	30	



2M Async Fast SRAM

CS18FS2048(3/W)

		$V_{IL}, I_{OUT} = 0mA$	12ns	28	
			15ns	25	
Standby Current	I_{SB}	Min. Cycle, $\overline{CS} = V_{IH}$	-	15	mA
	I_{SB1}	$f=0MHz, \overline{CS} \geq V_{CC}-0.2V$ $V_{IN} \geq V_{CC}-0.2V$ or $V_{in} \leq 0.2V$	-	9	
Output Low Voltage Level	V_{OL}	$V_{CC}=3.0V, I_{OL}=8mA, 3.3V$ Product & Wide V_{CC}^{**} Product	-	0.4	V
		$V_{CC}=2.4V, I_{OL}=1mA, Wide V_{CC}^{**}$ Product	-	0.4	
		$V_{CC}=1.65V, I_{OL}=0.1mA, Wide$ V_{CC}^{**} Product	-	0.2	
Output High Voltage Level	V_{OH}	$V_{CC}=3.0V, I_{OH} = -4mA, 3.3V$ Product & Wide V_{CC}^{**} Product	2.4	-	V
		$V_{CC}=2.4V, I_{OH} = -1mA, Wide V_{CC}^{**}$ Product	1.8	-	
		$V_{CC}=1.65V, I_{OH} = -0.1mA, Wide$ V_{CC}^{**} Product	1.4	-	

*The above parameters are also guarantee for industrial temperature range.

**Wide V_{CC} Range is 1.65V ~ 3.6V

Capacitance*($T_A = 25^\circ C, f = 1.0MHz$)

Item	Symbol	Test Conditions	TYP	Max	Unit
Input/ Output Capacitance	$C_{I/O}$	$V_{I/O}=0V$	-	8	pF
Input Capacitance	C_{IN}	$V_{IN}=0V$	-	6	pF

*Capacitance is sampled and not 100% tested.



2M Async Fast SRAM

CS18FS2048(3/W)

Test Conditions*

Parameter	Value
Input/ Output Capacitance	0 to 3.0V ($V_{CC}=3.3V$)
	0 to 2.5V ($V_{CC}=2.5V$)
	0 to 1.8V ($V_{CC}=1.8V$)
Input Rise and Fall Time	1V/1ns
Input and Output Timing Reference Levels	1.5V ($V_{CC}=3.3V$)
	$1/2V_{CC}$ ($V_{CC}= 1.8V$ or $2.5V$)
Output Load	See Fig. 1

*The above parameters are also guaranteed for industrial temperature range.

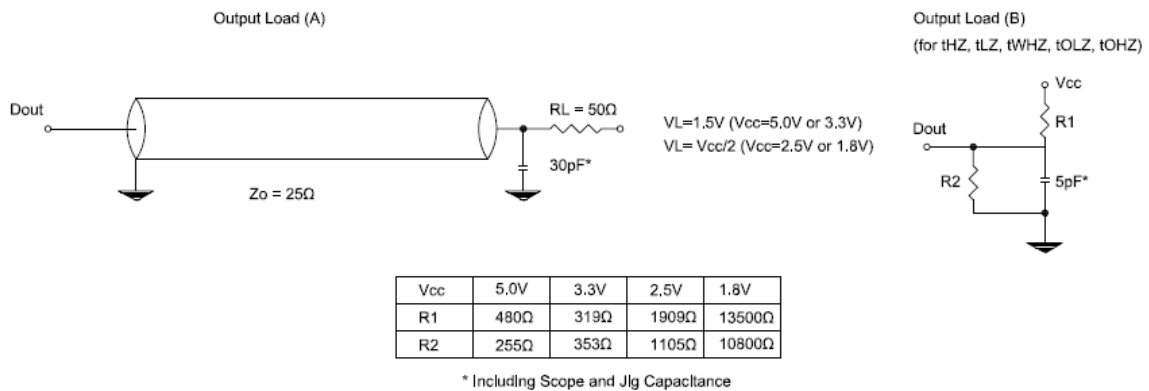

Fig 1



2M Async Fast SRAM

CS18FS2048(3/W)

Overshoot Timing

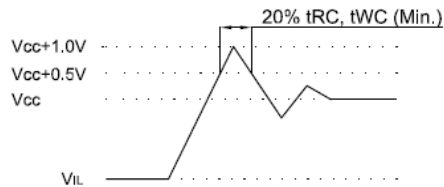

Undershoot Timing

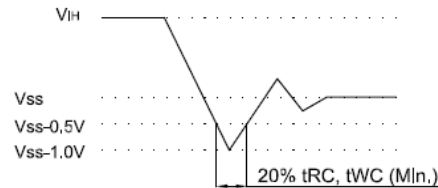

Fig 2

Functional Description (x8 Mode)

\overline{CS}	\overline{WE}	\overline{OE}	Mode	I/O Pin	Supply Current
H	X	X*	Not Select	High-Z	I_{SB}, I_{SB1}
L	H	H	Output Disable	High-Z	I_{CC}
L	H	L	Read	D _{OUT}	I_{CC}
L	L	X	Write	D _{IN}	I_{CC}

*X means don't care

Functional Description (x16 Mode)

\overline{CS}	\overline{WE}	\overline{OE}	\overline{LB}^{**}	\overline{UB}^{**}	Mode	I/O Pin		Supply Current
						I/O ₀ ~I/O ₇	I/O ₈ ~I/O ₁₅	
H	X	X*	X	X	Not Select	High-Z	High-Z	I_{SB}, I_{SB1}
L	H	H	X	X	Output Disable	High-Z	High-Z	I_{CC}
L	X	X	H	H				
L	H	L	L	H	Read	D _{OUT}	High-Z	I_{CC}
			H	L		High-Z	D _{OUT}	
			L	L		D _{OUT}	D _{OUT}	
L	L	X	L	H	Write	D _{IN}	High-Z	I_{CC}
			H	L		High-Z	D _{IN}	
			L	L		D _{IN}	D _{IN}	



2M Async Fast SRAM

CS18FS2048(3/W)

*X means don't care

Data Retention Characteristics*(T_A=0 to 70°C)

Parameter	Product	Operating V _{CC} (V)	Symbol	Test Condition	Min.	Typ.	Max.	Unit
V _{CC} for Data Retention	3.3V Product	3.3	V _{DR}	$\overline{CS} \geq V_{CC} - 0.2V$	2.0	-	3.6	V
	Wide 2.4V~3.6V	2.5/3.3			2.0	-	3.6	
	Wide 1.65V~2.2V	1.8			1.5	-	3.6	
Data Retention Current	3.3V Product	3.3	I _{DR}	V _{CC} =2.0V $\overline{CS} \geq V_{CC} - 0.2V$	-	-	5	mA
	Wide 2.4V~3.6V	2.5/3.3		V _{IN} ≥ V _{CC} - 0.2V or V _{IN} ≤ 0.2V	-	-	6	
	Wide 1.65V~2.2V	1.8		V _{CC} =1.5V, $\overline{CS} \geq V_{CC} - 0.2V$, V _{IN} ≥ V _{CC} - 0.2V or V _{IN} ≤ 0.2V	-	-	6	
Data Retention Set-Up Time			t _{SDR}	See Data	0	-	-	nS
Recovery Time			t _{RDR}	Retention Wave form (below)	5	-	-	mS

Data Retention Wave form

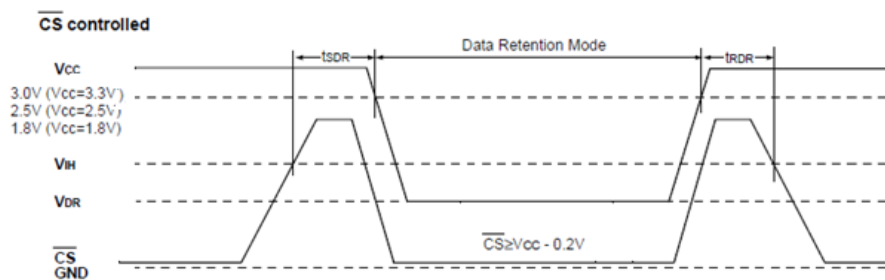



2M Async Fast SRAM

CS18FS2048(3/W)

Read Cycle*

Parameter	Symbol	8ns		10ns		12ns		15ns		Unit
		Min	Max	Min	Max	Min	Max	Min	Max	
Read Cycle Time	t _{RC}	8	-	10	-	12	-	15	-	ns
Address Access Time	t _{AA}	-	8	-	10	-	12	-	15	ns
Chip Select to Output	t _{CO}	-	8	-	10	-	12	-	15	ns
Output Enable to Valid Output	t _{OE}	-	4	-	5	-	6	-	7	ns
$\overline{UB}, \overline{LB}$ Access Time**	t _{BA}	-	4	-	5	-	6	-	7	ns
Chip Enable to Low-Z Output	t _{LZ}	3	-	3	-	3	-	3	-	ns
Output Enable to Low-Z Output	t _{OLZ}	0	-	0	-	0	-	0	-	ns
$\overline{UB}, \overline{LB}$ Enable to Low-Z Output**	t _{BLZ}	0	-	0	-	0	-	0	-	ns
Chip Disable to High-Z Output	t _{HZ}	0	4	0	5	0	6	0	7	ns
Output Disable to High-Z Output	t _{OHZ}	0	4	0	5	0	6	0	7	ns
$\overline{UB}, \overline{LB}$ Disable to High-Z Output**	t _{BHZ}	0	4	0	5	0	6	0	7	ns
Output Hold from Address Change	t _{OH}	3	-	3	-	3	-	3	-	ns
Chip Selection Power Up Time	t _{PU}	0	-	0	-	0	-	0	-	ns
Chip Selection Power Down Time	t _{PD}	-	8	-	10	-	12	-	15	ns

*The above parameters are also guaranteed for industrial temperature range.



2M Async Fast SRAM

CS18FS2048(3/W)

Write Cycle*

Parameter	Symbol	8ns		10ns		12ns		15ns		Unit
		Min	Max	Min	Max	Min	Max	Min	Max	
Write Cycle Time	t _{wc}	8	-	10	-	12	-	15	-	ns
Chip Select to End of Write	t _{cw}	6	-	7	-	9	-	12	-	ns
Address Set-up Time	t _{as}	1.5	-	1.5	-	1.5	-	1.5	-	ns
Address Valid to End of Write	t _{aw}	6	-	7	-	9	-	12	-	ns
Write Pulse Width(\overline{OE} High)	t _{wP}	6	-	7	-	9	-	12	-	ns
Write Pulse Width(\overline{OE} Low)	t _{wP1}	8	-	10	-	12	-	15	-	ns
$\overline{UB}, \overline{LB}$ Valid to End of Write**	t _{bw}	6	-	7	-	9	-	12	-	ns
Write Recovery Time	t _{wR}	1.5	-	1.5	-	1.5	-	1.5	-	ns
Write to Output High-Z	t _{whz}	0	4	0	5	0	6	0	7	ns
Data to Write Time Overlap	t _{dW}	4	-	5	-	7	-	8	-	ns
Data Hold from Write Time	t _{dH}	0	-	0	-	0	-	0	-	ns
End of Write to Output Low-Z	t _{ow}	3	-	3	-	3	-	3	-	ns

*The above parameters are also guaranteed for industrial temperature range.



2M Async Fast SRAM

CS18FS2048(3/W)

Timing Diagram

Timing Waveform of Read Cycle (1) (Address Controlled, $\overline{CS} = \overline{OE} = V_{IL}$, $\overline{WE} = V_{IH}$, \overline{UB} , $\overline{LB} = V_{IL}$ **)

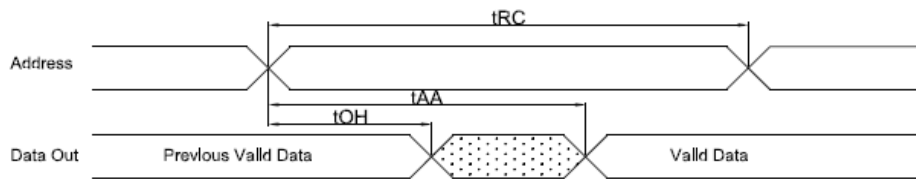

** Those parameters are applied for x16 mode only.

Timing Waveform of Read Cycle (2) ($\overline{WE} = V_{IH}$)

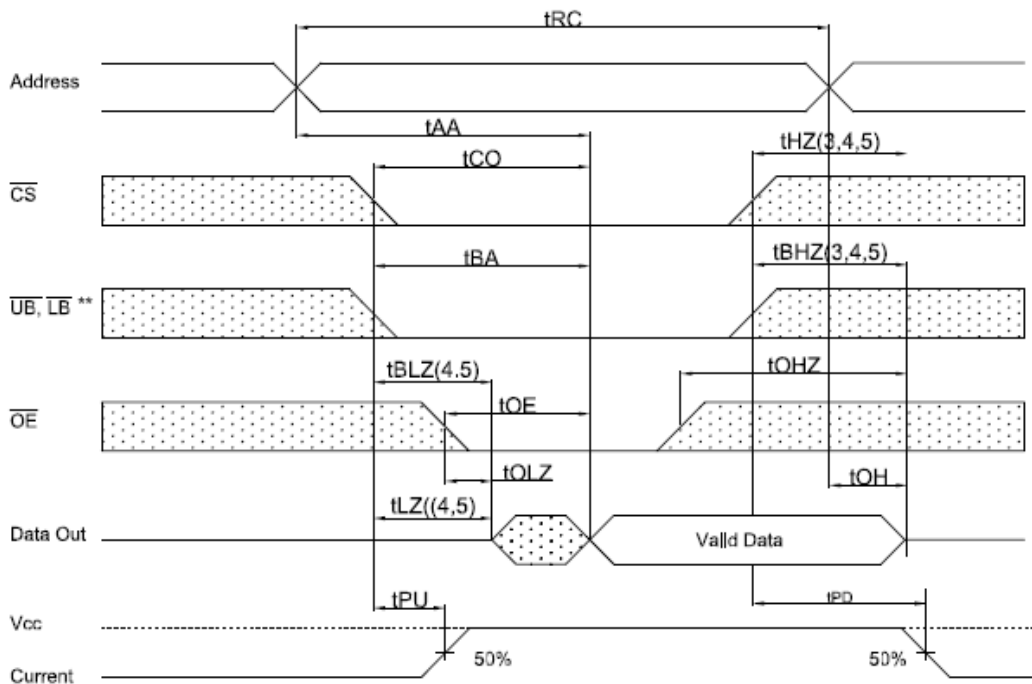

NOTES (Read Cycle)

1. \overline{WE} is high for read cycle



2M Async Fast SRAM

CS18FS2048(3/W)

2. All read cycle timing is referenced from the last valid address to the first transition address.
3. t_{HZ} and t_{OHZ} are defined as the time at which the outputs achieve the open circuit condition and are not referenced to V_{OH} or V_{OL} levels.
4. At any given temperature and voltage condition, t_{HZ} (Max.) is less than t_{LZ} (Min.) both for a given device and from device to device.
5. Transition is measured $\pm 200\text{mV}$ from steady state voltage with Load (B). This parameter is sampled and not 100% tested.
6. Device is continuously selected with $\overline{CS} = V_{IL}$.
7. Address valid prior to coincident with \overline{CS} transition low.
8. For common I/O applications, minimization or elimination of bus contention conditions is necessary during read and write cycle.

** Those parameters are applied for x16 mode only.

Timing Waveform of Write Cycle (1) (\overline{OE} Clock)

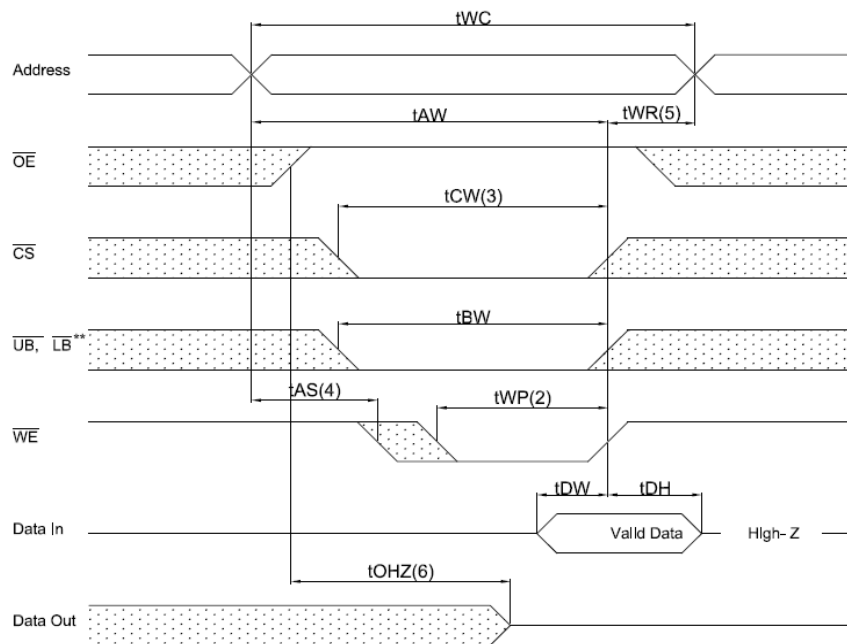

** Those parameters are applied for x16 mode only.



2M Async Fast SRAM

CS18FS2048(3/W)

Timing Waveform of Write Cycle (2) (\overline{OE} = Low fixed)

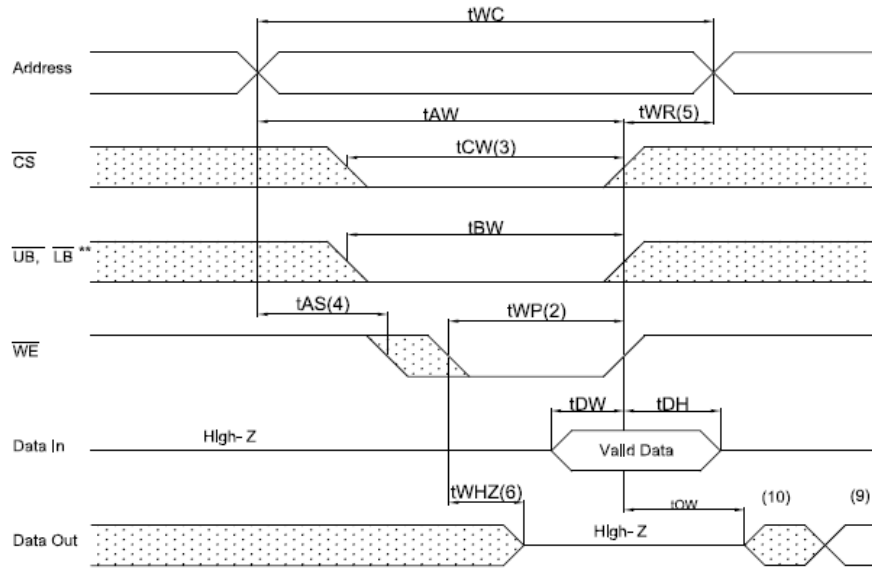

** Those parameters are applied for x16 mode only.

Timing Waveform of Write Cycle (3) (\overline{CS} = Controlled)

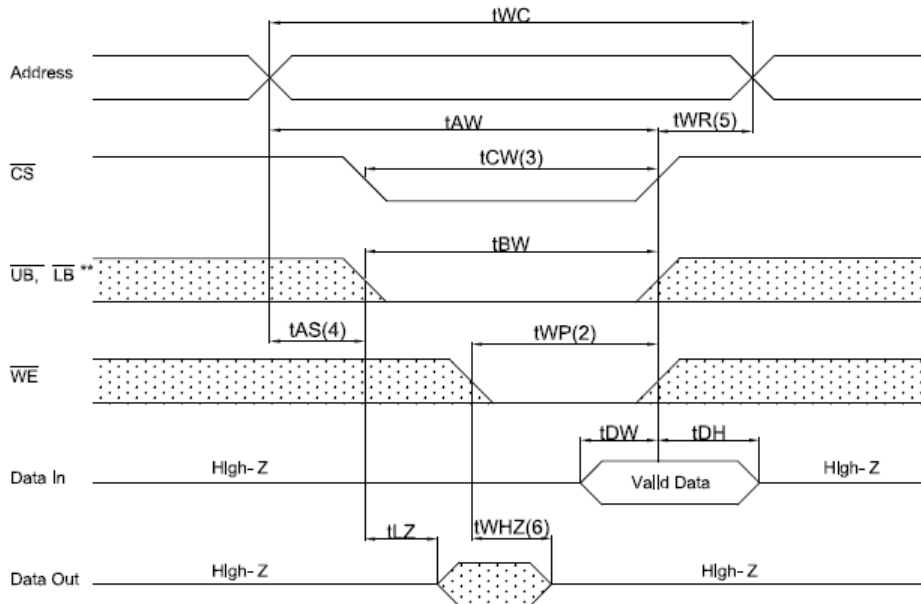

** Those parameters are applied for x16 mode only.



2M Async Fast SRAM

CS18FS2048(3/W)

Timing Waveform of Write Cycle (4) (\overline{UB} , \overline{LB} Controlled)

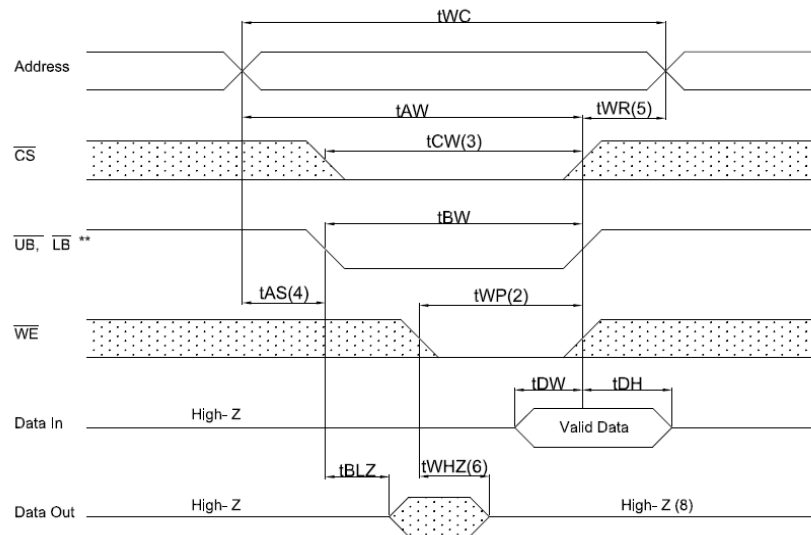

NOTES (Write Cycle)

- All write cycle timing is referenced from the last valid address to the first transition address.
- A write occurs during the overlap of a low \overline{CS} , \overline{WE} , \overline{LB} and \overline{UB} . A write begins at the latest transition \overline{CS} going low and \overline{WE} going low ;
A write ends at the earliest transition \overline{CS} going high or \overline{WE} going high. t_{WP} is measured from the beginning of write to the end of write.
- t_{CW} is measured from the later of \overline{CS} going low to end of write.
- t_{AS} is measured from the address valid to the beginning of write.
- \overline{WE} is measured from the end of write to the address change. t_{WR} applied in case a write ends as \overline{CS} or \overline{WE} going high.
- If \overline{OE} , \overline{CS} and \overline{WE} are in the Read Mode during this period, the I/O pins are in the output low-Z state. Inputs of opposite phase of the output must not be applied because bus contention can occur.
- For common I/O applications, minimization or elimination of bus contention conditions is necessary during read and write cycle.
- If \overline{CS} goes low simultaneously with \overline{WE} going or after \overline{WE} going low, the outputs remain high impedance state.
- D_{OUT} is the read data of the new address.
- When \overline{CS} is low : I/O pins are in the output state. The input signals in the opposite phase leading to the output should not be applied.

** Those parameters are applied for x16 mode only



2M Async Fast SRAM

CS18FS2048(3/W)

Package outline dimensions

44L-TSOP2-400mil

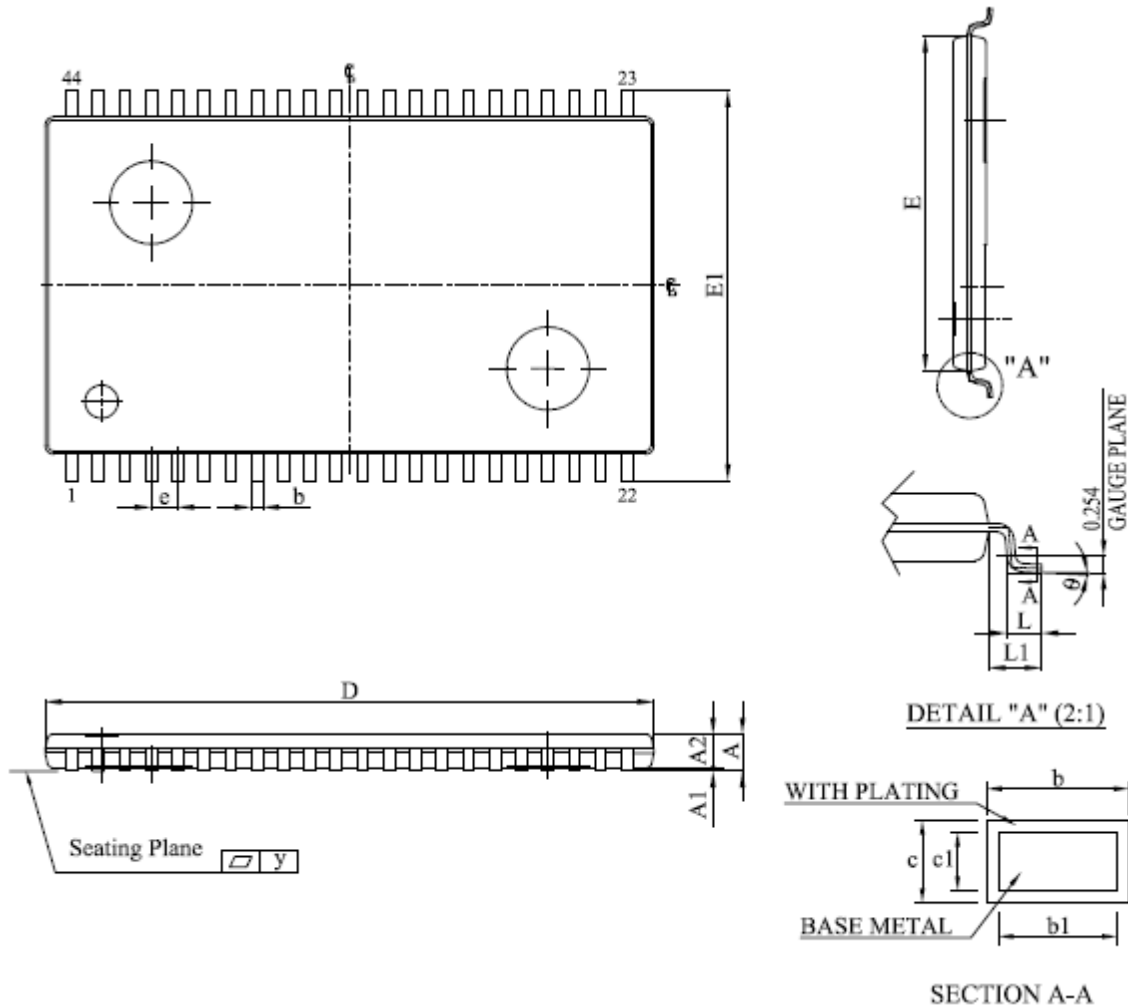

Note: Plating thickness spec : 0.3 mil ~ 0.8 mil.

SYMBOL UNIT	A	A1	A2	b	b1	c	c1	D	E	E1	e	L	L1	y	θ	
mm	Min.	1.00	0.05	0.95	0.30	0.30	0.12	0.12	18.31	10.06	11.56	0.70	0.40	0.70	-	0°
	Nom.	1.10	0.10	1.00	-	-	-	-	18.41	10.16	11.76	0.80	0.50	0.80	-	-
	Max.	1.20	0.15	1.05	0.45	0.40	0.21	0.16	18.51	10.26	11.96	0.90	0.60	0.90	0.1	8°
inch	Min.	0.0393	0.002	0.037	0.012	0.012	0.005	0.005	0.721	0.396	0.455	0.0275	0.0157	0.0275	-	0°
	Nom.	0.0433	0.004	0.039	-	-	-	-	0.725	0.400	0.463	0.0315	0.0197	0.0315	-	-
	Max.	0.0473	0.006	0.041	0.018	0.016	0.008	0.006	0.729	0.404	0.471	0.0355	0.0237	0.0355	0.004	8°



2M Async Fast SRAM

CS18FS2048(3/W)

36ball mini-BGA-6x8mm (ball pitch: 0.75mm)

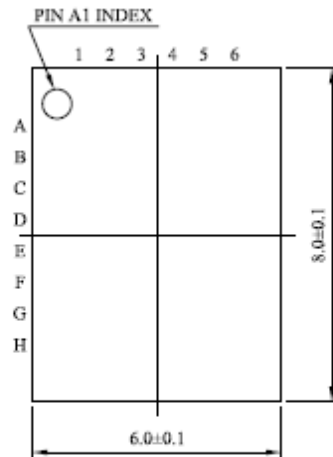

TOP VIEW

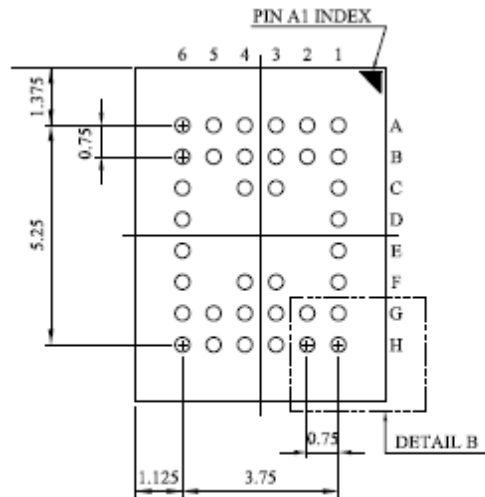

BOTTOM VIEW (BALL SIDE)

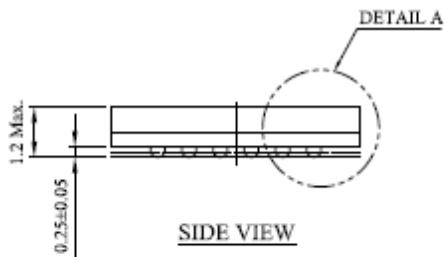

SIDE VIEW

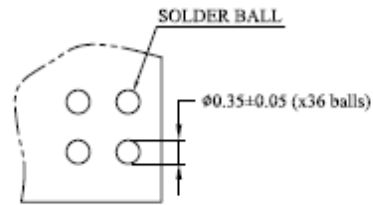

DETAIL B

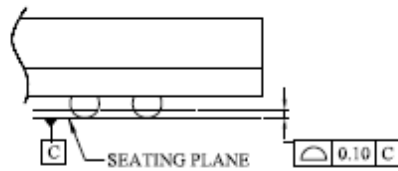

DETAIL A

- NOTES:
1. CONTROLLING DIMENSIONS ARE IN MILLIMETERS.
 2. PIN#1 DOT MARKING BY LASER OR PAD PRINT.



2M Async Fast SRAM

CS18FS2048(3/W)

48ball mini-BGA-6x8mm (ball pitch: 0.75mm)

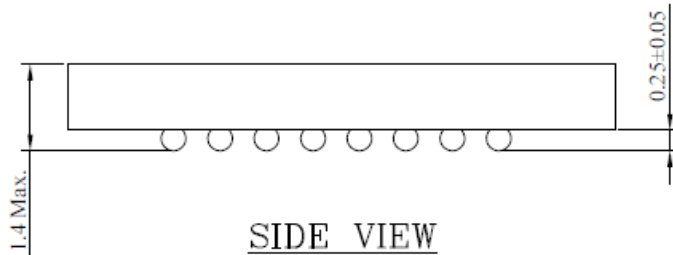

BALL PITCH e = 0.75				
D	E	N	D1	E1
8.0	6.0	48	5.25	3.75

